

SEA FROST®

372 ROUTE 4 BARRINGTON, NH 03825 USA
E-Mail: sales@seafrost.com

TEL (603) 868-5720

FAX (603) 868-1040

1-800-435-6708
www.seafrost.com

**OPERATION & INSTALLATION
INSTRUCTIONS
BG 2000
404a SERIES**

**C.F. HORTON & CO., INC.
372 ROUTE 4
BARRINGTON NH 03825
U.S.A.
(603) 868-5720
WWW.SEAFFROST.COM**

SEA FROST is a registered trademark of C.F. Horton & Co., Inc.

***Aspects of the SEA FROST design are covered by
US Patent # 4,356,708***

Copyright © 2001 by C.F. Horton & Co., Inc.

TABLE OF CONTENTS

| | |
|-------------------------------------|-------|
| BG 2000 OPERATION | 4 |
| ICE MAKING | 5 |
| MAINTENANCE | 6 |
| HOW REFRIGERATION WORKS | 8-9 |
| INSTALLATION | 10 |
| SWAGELOK FITTINGS | 11-13 |
| CONDENSING UNIT LOCATION | 14 |
| VALVE | 15 |
| PUMP INSTALLATION | 16 |
| THERMOSTAT | 17 |
| RFD | 17 |
| ACCESS TO THE SYSTEM | 19 |
| GAUGES | 20 |
| LEAK CHECKING | 22-23 |
| NEW SYSTEM CHARGING | 22-23 |
| READING THE SIGHT GLASS | 25-26 |
| CHECKING THE CHARGE / ADDING CHARGE | 26-27 |
| TROUBLESHOOTING | 28-30 |
| SPECIFICATIONS | 31 |
| ACCESS PORT LOCATION (DWG) | 32 |
| WATER CIRCUIT (DWG) | 33 |
| SINGLE ZONE (DWG) | 34 |
| BG2000 110-VOLT WIRING | 35 |
| BG2000 220-VOLT WIRING | 36 |
| THERMOSTAT CALIBRATION | 37 |
| MARCH PUMP DESCRIPTION | 39 |

NOTICE OF RESPONSIBILITY

It is the SEA FROST/ C.F. Horton & Co., Inc. intent to provide the safest, most accurate and detailed instructions. SEA FROST/ C.F. Horton & Co., Inc. cannot be responsible for problems or damage caused by omissions, inaccuracy or interpretations of these instructions.

A VIEW OF THE FUTURE:

As a once wonderful invention, refrigerants are now the latest enemy as our awareness of the universe increases. To the end regarding conservation we have always offered a leak proof system. We have also always designed our systems to operate with the lowest quantity of refrigerant. We are concerned.

There is a global impact from all refrigerants and it is time now to address the concept of "invisible pollutants".

Your new R-404a system has little environmental impact that we know of at this time. This not to say those millions of tons of refrigerant won't make some problem in the future. We must enjoy the benefits of refrigeration but be conscious of the maintenance of the machinery to avoid unnecessary leaks and waste. Everyone must be involved.

Thank you for supporting our product. We are proud to be providing what we feel is the best equipment available, bar none.

Cleave Horton

BG 2000 OPERATION

The *SEA FROST BG 2000* system is an electrically driven refrigeration plant. Operation of the compressor will freeze the contents of the holdover devices in the boat's icebox providing refrigeration by cold holdover for an extended period after the compressor has been turned off. A boat without continuous power can benefit from this by operating the *SEA FROST BG 2000* system when the generator plant is operated. Operation time will vary with each boat.

A little time-spent learning about your system and some experimentation will be best. Maximum holdover will be reached when the cabinet is at the desired temperature and the holdover plates are frozen. Running times beyond this have no advantage other than to delay warming the plates.

The system is water-cooled. Water should begin to flow from the discharge at the same time the unit starts. Be sure the water is flowing. If no water flows, stop the system and inspect the water pump and strainer for obstructions. (See "Troubleshooting" and "Maintenance" sections.)

After starting a warm system check the plates for a temperature drop. If a temperature drop is not indicated, stop the unit and read; "Checking The Charge", and; "Reading The Sight Glass".

CONTROLS

The BG 2000 thermostat control is labeled with "off", one, two, and three snowflakes. When the boat's breaker panel is switched on and AC power is available, turning the knob from "off" to one snowflake will start the compressor. Turning the knob to three snowflakes will increase the time the compressor operates, making the temperature cooler. Experiment with the control position to obtain the best setting.

ICE MAKING

Your **SEAFROST** holdover plate may be equipped with vertical ice trays. The ice trays are held in contact with the plate by a stainless steel rod.

Fill the vertical trays with water and hang them on the face of the plate. Try to get some water between the tray and the plate surface to increase the thermal contact (increasing freezing ability).

HARVESTING ICE

Plan to wait some time after the trays are frozen for them to thaw in a sink or away from the plate in the refrigerator. When the outside surface is wet, invert the tray and let the ice slide out.

STORAGE OF ICE CUBES

After ice has been made and harvested, store it in resealable plastic bags in the refrigerator or if so equipped in the freezer. Ice trays left in contact with the plate will melt rapidly if the plate goes above freezing.

DEFROSTING

It is important to defrost the holdover plate regularly; this will maximize the efficiency of the system and ice making performance. It is not necessary to turn off the system to defrost. Scrape off any frost with a piece of wood or galley utensil. A noticeable drop in the cabinet temperature will occur.

BAG STYLE ICE MAKING

If your SEA FROST system is not equipped with the vertical tray kit, you can still make ice. One method is to use zip-lock bags. When filled with water a clip binder or a clamp of your own invention can hold the bag in contact with the plate.

BG 2000 MAINTENANCE

Like your engine, your SEA FROST needs periodic checking.

ROUTINELY CHECK:

1. The refrigerant charge. See: "Checking The Charge" text. *NEVER OPERATE SYSTEM WITHOUT PROPER CHARGE.*
2. All components, all tubing, fittings, and hose clamps for corrosion and wear. *BE SURE TO LOCATE AND INSPECT ALL FITTINGS AND COMPONENTS IN THE SYSTEM. KNOW THE LOCATION OF ALL CONNECTION POINTS.* Spray with a rust inhibitor REGULARLY. Corrosion unchecked in the marine environment will severely reduce the life of your system.

CLEANING

The holdover plate surface protects itself with a layer of oxidation. You might find that after a long period of storage the plate will look chalky. This will not effect operation and is easily cleaned up with a pot scrubber and soap.

WATER STRAINER

The water pump must be protected from damage and blockage by a seawater strainer. This strainer must be inspected and cleaned routinely.

ROUTINE SERVICE AND INSPECTION

We recommend sea strainer inspection before leaving the boat unattended dockside with the unit on. A visual inspection may be adequate depending on the type of strainer. To clean most types of strainers, close the seacock, open the strainer, remove the screen or basket, clean, reassemble and open the seacock. Operate the system and check for water flow and leaks around the strainer opening.

PUMP IMPELLER INSPECTION (if pump is inoperative)

The LC-3P pump is a sealed liquid cooled magnetic drive centrifugal pump. The impeller may be inspected for obstructions and wear by first closing the seacock. Drain the pump housing by removing a hose.

It is **IMPORTANT** that **NO WATER** flows between the plastic housing and the pump body. The screws that hold the cover also seal the housing. Water behind the housing will ruin the motor bearings.

BE SURE THE PUMP HOUSING IS ABSOLUTELY DRY BEFORE DISASSEMBLY.

Remove the phillips screws holding the inlet fitting plate (larger hose size). The impeller may then be removed along with it's ceramic seal and thrust washer. Reassemble in the reverse order. (An exploded diagram is in this manual.) Observe the "O" ring that seals the housing cover plate. Make sure it is in good condition. Open the seacock. Inspect for leaks.

NEVER OPERATE THE PUMP WHILE DRY. IF IT IS SUSPECTED THAT THIS CONDITION HAS OCCURRED, INSPECT THE IMPELLER AND HOUSING FOR WEAR.

CHECKING THE REFRIGERANT CHARGE

SIGHT GLASS LOCATION

The BG 2000 system is fitted with a sight glass located in the top of the RECEIVER/FILTER/DRIER (RFD). (The RFD is a round blue canister about 9 inches high and 3 inches in diameter. It is located in the left corner of the compressor housing.)

The charge level should be inspected to be sure refrigerant is of the proper amount and that there are no slow leaks. Switch the unit on and immediately inspect the sight glass. White foam with high velocity should be observed and after a minute or two show a black or clear condition. A clear glass and an empty glass will look the same. A transition must be seen to be sure that refrigerant is present. Do not operate a low or empty system. See; "Leak Checking" and "Adding Charge". (Page 22)

LAY-UP (Winterizing)

Flush the pump and condenser with plenty of fresh water. Pressure water should be flushed through the inlet side of the water pump. In freezing climates antifreeze should be pumped through, after flushing, by operating the system for a very brief period. Connect a short hose to the suction side of the pump to draw from a bucket. Run the pump (switch on unit) until antifreeze is discharged. (The pump is not self-priming and may require filling the hose and pump with a funnel). **DO NOT RUN THE PUMP DRY.** It is water lubricated.

HOW REFRIGERATION WORKS

There are two important concepts to understand in order to learn about refrigeration. They are latent heat and phase changes.

A great deal of heat is required to change a solid to a liquid, and a liquid to a gas. A great deal of heat must be removed to reverse these changes. These changes are called phase changes, or changes of state. The heat removed or added at these phase changes has no effect on the temperature of the substances until the change is complete. For instance, ice melts at 32 degrees F, water freezes at 32 degrees F also. Ice and water will remain at 32 degrees F until the freezing or melting process is complete. Latent heat is this hidden energy required to make or break the bonds in a phase change.

By evaporating liquid to a vapor, we can absorb heat. By condensing a vapor to a liquid, we give up heat. Refrigeration is the use of these phase changes to move heat out of the icebox (cooling it).

We all know that cold is the absence of heat. A practical example of heat absorption by evaporation is that of rubbing alcohol evaporating in your hand and cooling it. The alcohol is actually using the heat from your hand to boil. The absorption of heat cools your hand.

Pressure affects the temperature at which a gas phase change will occur. Using water as an example, water boils at sea level at 212 degrees F. On top of Mt. Everest it boils at a much lower temperature. The air pressure is lower allowing the water-to-steam phase change to occur more easily. A pressure cooker increases the pressure on water to restrict boiling to a higher temperature. A pressure cooker will cook food faster because the temperature is higher. Remember that a phase change involves latent heat. The temperature of boiling water is only 212 degrees F. at sea level. The evaporation action is absorbing heat at a rate equal to the rate of heat applied, preventing further temperature rise.

Let's look at Refrigerant-404-a (R-404-a). R-404-a will boil at minus 57 degrees F. at sea level. By evaporating liquid R-404a in the SEA FROST plates heat is absorbed making refrigerant vapor. To dispose of this heat, a condensing phase change is necessary. By increasing the pressure (compressing) we can raise the boiling point of the gas vapor. Heat is removed from the pressurized gas vapor at the condenser. Seawater passing the condenser coils removes the heat, forcing the vapor to a liquid state again. Pressure, therefore, is the key that allows passing the heat we have taken from the icebox to a warmer place (the seawater) and converting the gas to a liquid to be re-evaporated again.

By causing R-404a to boil (evaporate) in the SEAFROST plates, we absorb the heat energy there. This activity cools the liquid solution within the plates, causing them to change phase (freezing to a solid). By freezing this solution, we have increased its heat absorption capacity more than 100 times.

When the cycle is stopped (compressor is turned off) the plates will begin to absorb the heat that leaks through the insulation in the icebox. The absorption will be at a constant temperature until the phase change to liquid (melting) is complete. This is the principle of holdover refrigeration and the function of your SEA FROST.

INSTALLATION

Installer's care should be stressed. No matter how good SEA FROST equipment is, its performance and life are in the hands of the installer. To insure your work:

1. Read this manual.
2. Reread any aspect you don't understand.
3. Follow Swagelok fitting instructions carefully.
4. Spend enough time leak-checking to be sure there are no leaks.
5. Thanks from all of us who have to guarantee your work.

There are two contaminants that will give you problems in any refrigeration system. They are WATER and DIRT. Moisture is always present and cannot be eliminated, water in this case refers to puddles and drops. Dirt is any solid. The installer's habits will be most important in ensuring a trouble-free start-up. We have added a large receiver filter dryer (RFD) to take care of all dirt and moisture that might get into the system during a careful installation. Moisture in the system is boiled off when the system is evacuated, or it is captured in the desiccant. There is a screen in the expansion valve to prevent dirt from plugging it.

Excess moisture that the RFD can't handle will plug the expansion valve with ice. This ice stops the cycle. The only cure is to discharge the refrigerant, replace the RFD, re-evacuate the system, and recharge it. This remedy takes time and is somewhat costly. Keep the system clean when installing it to save time for something more fun.

TUBE HANDLING

Installation is quite simple. All the copper tube comes to you with the ends capped. Any routing of the tube must be done with the tube either taped or capped. Cap both tube ends after each cut. (Spare caps have been included). Work with only one line at a time, and only uncap one end at a time.

TUBE CUTTING

Use only a tube cutter; hacksawing or any other method will introduce chips to the system and also distort the tube, making connections difficult and leak-prone. A miniature cutter is essential for this work. CUT SLOWLY to avoid a ridge on the inside of the tube. We do not recommend reaming or dressing the cut, as it is very easy to get chips of copper in the system, which may cause trouble.

TUBE BENDING

Make all but the long sweep bends with a spring bender; one kink and the line must be rerun. Don't add any more fittings than are absolutely necessary. Route all lines in such a way that they are most direct but out of the way. Again, keep everything sealed until you are ready to make that connection.

NOTES ON SWAGELOK FITTINGS

Swagelok fittings come to you completely assembled, finger-tight. (Pieces a, b, and c in Drawing #1 are already together). They are ready for immediate use.

Disassembly before use can result in dirt and foreign material getting into the fitting and causing leaks. If disassembly is necessary, reassemble per Drawing # 1.

This is a double ferrule system. The most serious installation problem encountered with SEA FROST is the incorrect assembly of these fittings. Be absolutely sure that you assemble all fittings as in Drawing #1.

To ease assembly slacken the fitting nut slightly before pushing onto the tube, then retighten with fingers before tightening with a wrench. (This is to avoid cross threading.)

Step 1. Always leave two inches of straight, undistorted tubing leading to all Swagelok fittings to allow a proper connection.

Step 2. Prior to inserting 1/2" tubing into Swagelok tube fitting, make a pencil mark one inch from the end of the tube. Prior to inserting 3/8" tubing, make a pencil mark 3/4" from the end of the tube. With 1/4" tubing make the mark 5/8" from the end.

Step 3. Insert clean, smooth tubing with the pencil mark into the Swagelok tube fitting. You can be sure the tube is resting firmly on the shoulder of the fitting when the pencil mark is flush with the nut.

Step 4. Tighten the Swagelok nut to a wrench snug* position. Scribe the nut with a pencil at the 6:00 o'clock position. (See drawing #1 step # 2.)

* Wrench snug is the first point in the assembly tightening when the tube can not be pulled from the fitting, (i.e. when the ferrules tighten enough to contact the tubing).

Step 5. Now, while holding the fitting body with a back-up wrench, tighten the nut one-and-one-quarter turns (1-1/4). To do so, watch the scribe mark, make one complete revolution, and continue to the 9:00 o'clock position. (See drawing # 1, step #3.)

DRAWING 1



STEP 1

Simply insert the tubing into the SWAGELOK tube fitting. **Make sure that the tubing rest firmly on the shoulder of the fitting and that the nut is wrench snug.**

STEP 2

Before tightening the SWAGELOK nut, scribe the nut at the six o'clock position.



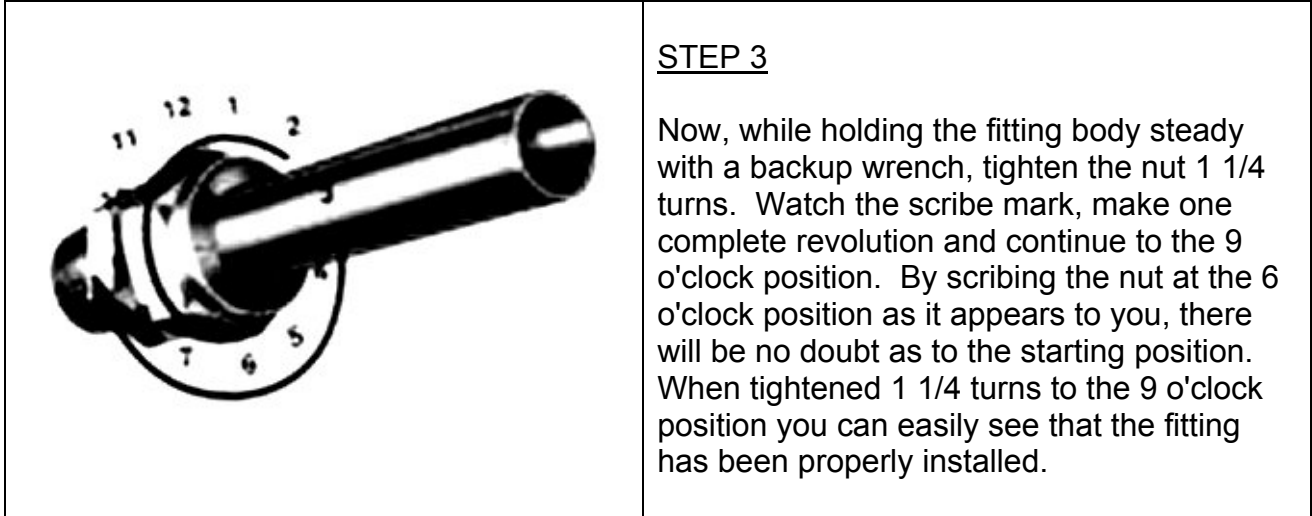

* SWAGELOK FITTINGS ARE TO BE TIGHTENED TO A TORQUE SPEC, NOT INFINITE TIGHTNESS. BE SURE YOUR STARTING POINT IS WRENCH SNUG. (SEE STEP 4 on page 12.) A DISTORTED TUBE MIGHT GIVE A FALSE STARTING POINT.

* Swagelok fittings have a built-in spring interaction between the ferrules. This compensates for temperature changes and allows the fittings to be reconnected many times. As the fitting is tightened, a burnishing occurs between the body of the fitting and the ferrules and between the ferrules and the tube. This action provides the tightest connection available.

* When making all connections, USE TWO WRENCHES. Don't allow the fittings to turn or twist when tightening.

RECONNECTING PRE-SWAGED FITTINGS

Connections can be disconnected and retightened many times.

When reconnecting, insert the tubing with pre-swaged ferrules into the fitting until the front ferrule seats in the fitting. Tighten the nut by hand to prevent cross threading. Tighten the nut one-quarter of a turn with a wrench (or to original one-and-one-quarter tight position). Then snug slightly with the wrench. No more than an additional 1/8 turn.

CONDENSING UNIT LOCATION AND MOUNTING

The design of the BG 2000 allows placement of the unit in an enclosed space such as a cabin locker, sail locker or engine area.

The BG 2000 is a high-powered unit. It produces some noise and vibration. Its duty cycle will be short however, consider that dockside operation may be noticed when the generator is not masking the sound. Bulkhead mounting is fine, but avoid mounting on a bulkhead that may resonate into the cabin area. If an under bunk installation is used, turning off the thermostat at night will avoid startling you should the unit start.

SERVICE ACCESS

Service access and installation require that the front and left end (water fitting end) be accessible.

RECEIVER FILTER DRIER (RFD) VISIBILITY

LOCATION: The RFD is in the left corner of the compressor unit. Be sure that it can be viewed from the top. A mirror might be mounted above the glass to allow ease of inspection if the unit is to be mounted close to an overhang or under a deck.

MOUNTING

Mount the BG 2000 level. The unit may be bulkhead or platform mounted. It may be hung from its case. Use the aluminum ell brackets supplied. The 1/4-20 X 1-3/4 Stainless screws thread into the Well-nut mounts at the back corners of the housing. Mount holes for standard fasteners are also drilled in the forward edge of the bottom of the cabinet.

PLATE MOUNTING

SEA FROST holdover plates mount with a "Wellnut" expandable neoprene blind hole fastener. A template or the part itself should be used to locate the mounting holes. Drill 1/4" pilot holes then increase them to 1/2". Install the screw into the mounting tab then screw the mount onto the screw. Install the plate pushing the rubber mounts into the predrilled holes. Tighten the screws firmly.

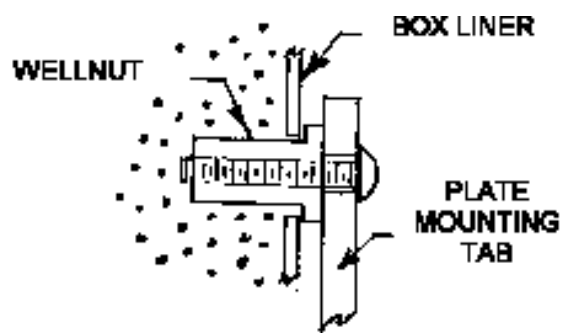

INSTALLING THE THERMOSTATIC EXPANSION VALVE

The larger fitting on the thermostatic expansion valve connects with a Swagelok to one of the plate tubes. In a multiple plate series system $\frac{1}{2}$ " copper jumper lines will connect the plates to each other. The last plate has a $\frac{1}{2}$ " return line to the compressor. The feeler bulb from the valve must be strapped to this return line inside the refrigerated space. Plan the tube run to allow for the length of the capillary (about 50 "). On a vertical run the capillary tube connection should be up above the bulb. It is critical that the feeler bulb be in excellent contact with the copper tube. Be sure to locate the feeler on a straight section of tube. Strap the bulb to the line with the two copper straps, bolts, and nuts. Coil and secure the excess capillary tube between the valve and bulb with nylon cable ties. Do not let the capillary tube contact other tubes or the plate surfaces.

The valve is supplied by a $\frac{1}{4}$ " copper tube from the compressor. This is a Swagelok connection.

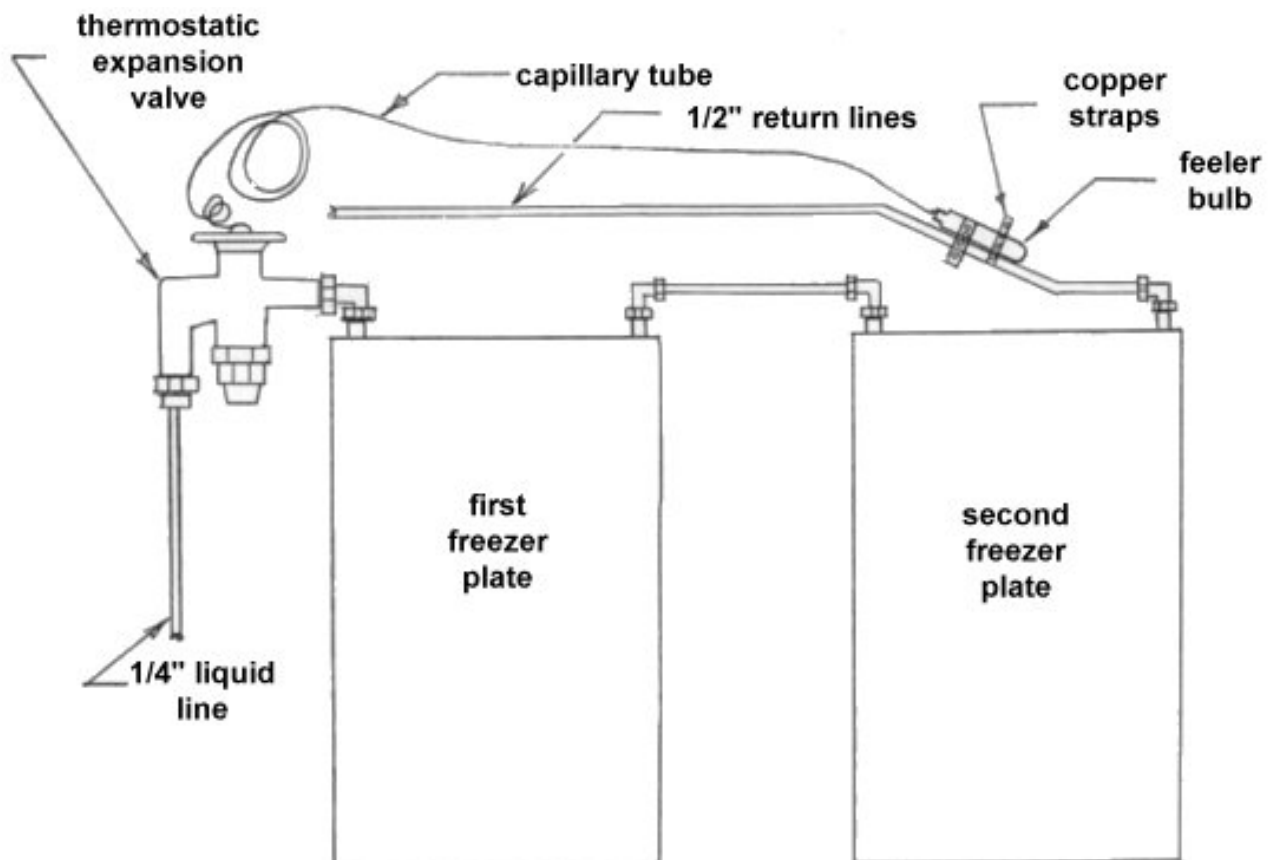

RUNNING THE TUBING

Make the connection to the compressor and RFD after all other connections are made.

A 1/4" copper tube runs between the compressor unit and the expansion valve. Multiple plate hook-ups should be assembled as indicated by the specific diagram provided.

A 1/2" line connects the plate outlet to the compressor. If possible run the 1/4" liquid line in contact with the 1/2" line. This will be insulated in proper sequence. Support the tubing every 12 to 18 inches as necessary with tie wraps after leak checking and insulating.

PUMP INSTALLATION

Proper pump installation is important for pump operation. The BG 2000 uses a centrifugal pump, which is not self-priming. Air pockets caused by loops or descending lines from one component to the other may cause pump problems. This pump is water cooled and lubricated, it must never be run dry, doing so will cause the wet end to be destroyed if it is started or run dry. A separate through hull fitting 3/4" or larger should be used. The intake should be as low in the boat as possible and away from head and cockpit drains. A forward facing scoop will prevent problems if the unit is operating underway.

A large seawater strainer should be mounted above the seacock.

The pump should be mounted horizontally and it should be higher than the strainer. The discharge should be on the top. Refer to the pump drawing at the back of this manual.

WARNING: READ SAFETY SECTION BEFORE PROCEEDING

FINAL ASSEMBLY

The RFD contains desiccant to absorb moisture and the compressor oil is hydroscopic therefore it is important to open the compressor and RFD fittings after all other connections are made and the system is ready to be commissioned.

The BG 2000 unit is shipped with some nitrogen pressure. Before removing the caps on the connection ports remove the screw caps on the access valves and depress the cores with a clean retracted pen point to vent any existing pressure.

After depressurizing, working with one connection at a time, remove the Swagelok caps from compressor and liquid line. Attach in the proper assembly sequence the front and back ferrules and the Swagelok nuts. (Refer to the Swagelok instructions on page 12.)

RFD (Receiver Filter Drier)

The RFD contains desiccant to absorb moisture. This absorption is limited. *Leaving the RFD installed on a partially open system may reduce its capacity by allowing it to absorb moisture.*

The RFD is a reservoir for excess refrigerant. The RFD also contains a sight glass in the top. A pick-up tube extends from the bottom of the canister to the outlet.

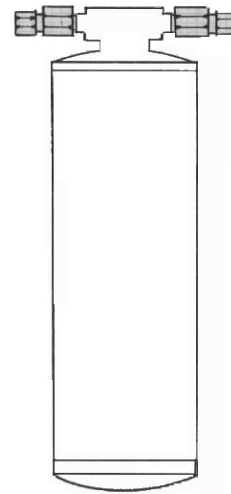

THERMOSTAT

For the best looking job the thermostat should be cut into a panel. (We do not recommend installation in the insulation or in the box, as the control is not moisture protected.) A cutting template is provided. Locate the thermostat close enough for the "bulb" tube to reach. It is only necessary that the bulb end of the sensing tube be installed on the plate. Use one of the mount screws for attaching the thermostat bulb clip to the plates. Secure any excess in a coil in the refrigerated space. Do not allow the sensing tube to contact any of the copper tubes. *The sensing tube is hollow and filled with refrigerant; avoid bending it, which could cause it to crack and leak. Excess capillary tube should be left in the refrigerated box.*

THERMOSTAT WIRING

The thermostat electrical leads are low voltage for safety. Connect the red thermostat wires to the two terminal screws in the BG 2000 terminal box. Use the # 8 ring terminals provided.

AC LINE CIRCUIT

A separate 30-AMP breaker is required for the 110 volt AC circuit. A 15 amp double breaker should be used on a 230-volt unit. We recommend following ABYC guidelines for wire specifications and wiring procedures.

CONNECTION ACCESS

Remove the two screws in the front panel to reveal the line terminal board, pump supply, and thermostat connections.

WIRING THE PUMP

The pump is connected by three wires at the compressor unit. The pump operation is controlled by the BG2000.

REFRIGERANT HANDLING AND SAFETY

Do not proceed with any aspect of a procedure if you do not fully understand the procedure and know what result to expect. Understand that pressure exists in refrigeration systems. Be careful.

REFRIGERANT

SEAFROST is charged with REFRIGERANT-404a. REFRIGERANT-404a is a blend of HFC refrigerants. It is odorless. Its boiling point is -57. Degrees F. at sea level. It is heavier than air. It's label and container color is orange.

GENERAL SAFETY THIS IS IMPORTANT. READ THIS!

R-404a is safe if handled properly. Avoid breathing vapors and prolonged skin exposure. Avoid using in areas of open flames. The vapor is heavier than air and may reduce oxygen available for breathing. Use with sufficient ventilation to keep exposure below recommended limits. **Do not mix with air for leak testing or use with air for any purpose above atmospheric pressure.** Liquid R-404a will freeze skin. It's especially dangerous to the irreparable tissues of the eyes.

--WEAR EYE PROTECTION--

Do not pressurize an empty system with R-404a without first evacuating the system with a vacuum pump.

WARNING: **DANGER** NEVER OPERATE A SYSTEM WITH THE HIGH SIDE (DISCHARGE) OPEN TO THE REFRIGERANT SUPPLY. PRESSURIZATION OF THE REFRIGERANT SUPPLY COULD CAUSE IT TO BURST.

PROCEDURES FOR WORKING WITH R-404a

- 1)** A new uncharged system must be evacuated before adding R-404a.
- 2)** An R-404a system must only be pressurized with R-404a or nitrogen.
- 3)** Only service tools dedicated to R-404a are to be used. No parts, tubing, fittings, receivers, dryers, service gauges, or any refrigerant carrying components may be fitted to a R-404a system from a used system or from a CFC based system. Damage caused by the use of parts not supplied by Sea Frost for a R-404a system will cancel all claims against Sea Frost.
- 4)** No oil is to be added to the BG 2000 system but polyolester oil supplied by Sea Frost, labeled and capped for BG 2000 use. No oil is to be added to a system without prior consultation with Sea Frost.
- 5)** The oils used in R-404a systems are moisture sensitive (hygroscopic). Do not leave any tube end or component connection open to air while assembling the system. Be sure to use only new capped copper tubing and be sure to cap the copper coil after cutting it.

ACCESS TO THE SYSTEM: SERVICE PORTS

The service ports are two small capped valves. The low-pressure valve is mounted on the BG 2000 compressor. The high-pressure valve is mounted on a copper tube in the cabinet behind the RFD. (See drawing pg. 33) The ports are standard ¼ inch male flares with core valves. Hose connections must have the proper core depressor insert in it to access the system.

Be sure the caps are installed tightly after charging or service.

NOTE: THIS SYSTEM IS DESIGNED FOR R-404a. IT MUST BE CHARGED WITH R-404a ONLY. ONLY DEDICATED R-404a GAUGES AND EQUIPMENT ARE TO BE USED. ANY CONTAMINATION FROM CFC BASED REFRIGERANTS WILL DESTROY THIS SYSTEM.

GAUGES

Gauges must be used in the evacuation and charging. They will provide information on the operation of the system when troubleshooting.

A gauge sets consist of two gauges installed in a manifold with two valves and hoses to connect the gauges to the system. The left gauge (blue) is a compound device; it indicates pressure and also vacuum. The right gauge (red) indicates pressure only. The valves open a center port (yellow) to the left or right side respectively. Operation of the valves is only necessary when moving refrigerant or evacuating. With the valves closed, the gauges read the pressures of the connection points.

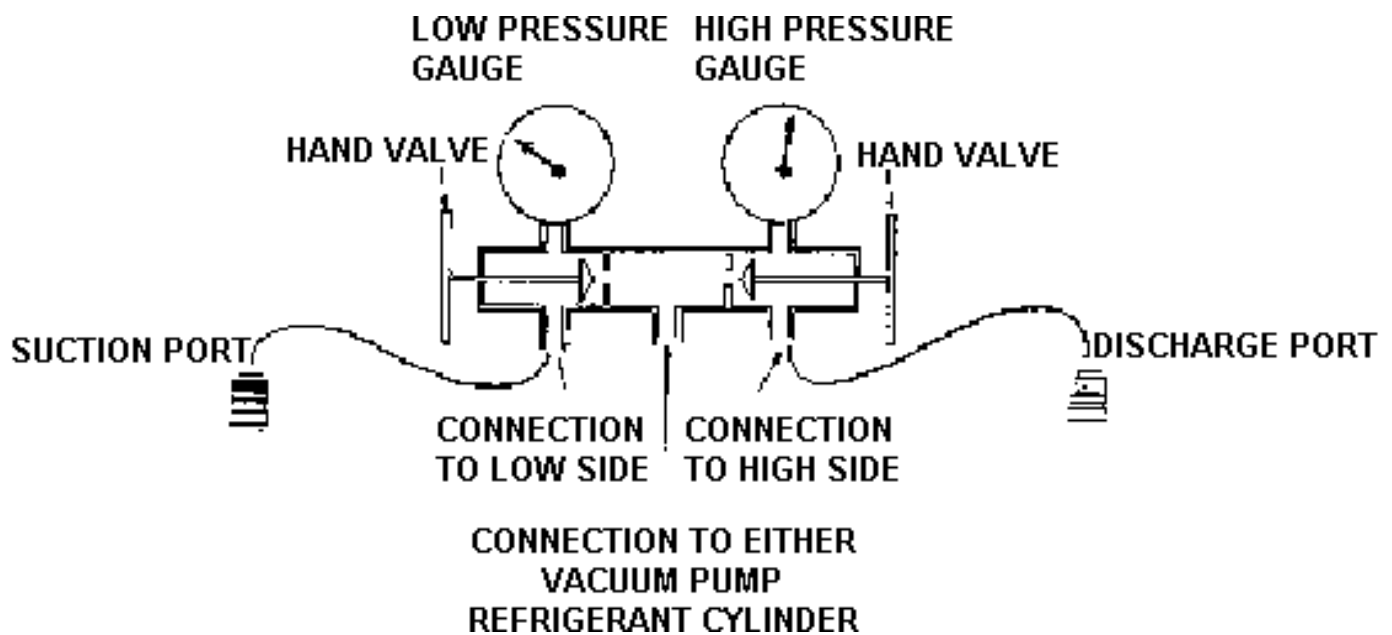

VENTING THE GAUGE SET

TO ATTACH TO A CHARGED SYSTEM

Before operating the compressor on a charged system vent the hoses for a few seconds by slacking the hose connections at the manifold body after connecting. This will prevent air trapped in the gauge hoses from entering the system.

DISCONNECTING GAUGES

Disconnecting the gauge set after running the system may be done by turning off the compressor and allowing the pressures to equalize on the gauges then rapidly unscrewing the hoses from the service ports.

Disconnecting the gauge set on a static system may be done by rapidly unscrewing the hoses from the service ports.

Adding charge to a working system should be done through the suction side (blue) as liquid. The suction pressure must be monitored and not allowed to rise more than 15 PSIG above operating pressure.

VENTING THE CHARGE HOSE

WHEN ATTACHING GAUGES TO A CHARGED SYSTEM

Note: This procedure will vary with the type of gauges being used. Be sure to vent the charge hose to the gauge set before opening the valve to add refrigerant.

LIQUID CHARGING

REFRIGERANT IS EITHER a vapor or liquid. R-404a is a blend that may separate if vapor charged. To supply LIQUID to a system, keep the refrigerant canister in the inverted position (valve down). If properly handled the refrigerant will flash to vapor when charging.

COMMISSIONING PROCEDURE

EVACUATION WITH A VACUUM PUMP

Evacuation removes air, readying the system for charging.

Connect a gauge set to the service ports. (See "Access Port Location" page 33)

Connect the gauge center hose to a high vacuum pump. Start the pump and slowly open the low side/suction gauge hand wheel. As the vacuum drops below 20 inches open both hand wheels fully.

EVACUATION LEAK TEST

Evacuate the system to the best vacuum (lowest pressure). As the gauge reaches this low pressure close the valves on the manifold. Observe the vacuum gauge and be sure the pressure remains constant for 5 minutes. If the pressure rises rapidly check all the connections again. Re evacuate to the lowest pressure and test by holding a vacuum with the gauges closed. Be sure the system will hold this vacuum. Proceed by opening the valves and continuing the evacuation process for 30 minutes or more. A micron gauge can be used to measure the vacuum. Proper dehydration and evacuation should be in the range of 200 to 500 microns.

NEW SYSTEM CHARGING

INTRODUCING INITIAL CHARGE

After the evacuation leak test and pump down, shut off the manifold valves, disconnect the center hose from the pump and connect it to a cylinder of refrigerant. Vent the hose from cylinder (refrigerant supply) to the manifold. With the refrigerant can in the inverted (liquid) position, open the discharge side valve (high side) valve and weigh in about 6 oz of refrigerant. This should provide a saturated vapor producing a pressure matching the pressure temperature chart. Close the valve and begin an inspection of all the connections in the system. Begin leak checking the entire system.

LEAK CHECKING

Leak checking is a very important step, which should be done with diligence. A leak will cripple this system. Please take the time needed to be sure all connections are tight. ***Check every connection even the ones that were pre-made in manufacture.***

The evacuation leak test is a preliminary check and is not to be considered a system leak check.

LEAK CHECKING A CHARGED SYSTEM

ABOUT PRESSURES

Refrigerant in a saturated condition, i.e. part liquid and part vapor, will exert a pressure that is a function of its temperature. The higher the temperature, the higher the pressure. Avoid leak checking in cold weather or on a cold system.

A refrigerant leak will show with moderate pressure. (A leak is not a function of pressure. Pressure is only required to aid in detection).

There are two ways to leak-check a pressurized system:

1. Soap bubbles (a solution of dish soap and water works well).
2. An HFC electronic leak detector probe, which senses the presence of refrigerant molecules.

TO CHECK WITH BUBBLES

Soap each connection and observe all sides of the connection with a bright light and a mirror. A leak will blow bubbles. Without careful examination and plenty of pressure this test is not reliable.

TO CHECK WITH AN ELECTRONIC DETECTOR

Use a detector designed for HFCs. Slowly trace the area with the probe. Refrigerant is heavier than air, therefore, trace below the fitting. Most units can be calibrated to home in, on a leak. (See detector instructions). We use and recommend electronic detection. TIF brand detectors can accurately detect leaks as low as 1/2-oz loss per year. This sensitivity exceeds S.A.E. leak specifications. Be sure to test the operation of the detector before and after you leak check the system

IF A LEAK IS DETECTED

Try tightening the Swagelok nut slightly. (See "Swagelok fittings"). If the leak is not stopped, it is possible that the fitting was incorrectly assembled. Discharge (reclaim) the refrigerant, and then disassemble the fitting for inspection. After reassembly, proceed with evacuation leak test.

SPECIAL NOTE

- Be aware that propellants and solvents in sprays and foams may upset electronic detectors.
- To confirm a leak detected with a detector use bubbles and be sure it is a leak and not some erroneous vapor that is upsetting the machine.
- Electronic detectors do not function below 40.F.
- A good leak detector is able to pick up leaks as low as 1/2 oz per year.

FINAL CHARGING

This procedure must follow "Evacuation Leak Test" and "Introducing Initial Charge".

1. With the refrigerant supply still attached to the suction service port from the previous procedure, open the cylinder valve (and the appropriate gauge wheel).
2. While closely observing the sight glass in the RFD, start the compressor by switching on the circuit breaker and then turning on the thermostat.

3. The sight glass will show a stream of foam indicating a partial charge.
4. Introduce liquid refrigerant (liquid is supplied by keeping the cylinder inverted) at a controlled pressure regulated by slightly opening the blue hand wheel valve. Keep the low side pressure no more than 15 PSIG above the indicated operating pressure. Add refrigerant for 30 seconds then turn off the supply and observe the sight glass and cooling operation for 2 minutes before adding refrigerant the same way again. Repeat this filling and observing. At the time the return line frosts the sight glass should be clearing. Let the system operate for 30 minutes with a mostly clear glass before adding a small shot for good measure (4 oz). Do not exceed the 24 oz maximum charge amount regardless of the sight glass reading. Compare pressures with the pressure trends page 32. When a sufficient amount of refrigerant has been added to the system (A new system holds 24 oz. maximum) the sight glass will clear, indicating sufficient charge. When charging a hot system, (cabinet and plates over 80 degrees F) the sight glass will usually clear as the return line at the valve becomes frosted.
5. When observation and test operation have been completed, disconnect the gauges. Replace the service port caps.
6. Re-check all connection points for leaks.
7. Spray the acrylic coating, or similar rust inhibitor, on all the components and fittings while they are clean and dry.

READING THE SIGHT GLASS

A clear sight glass when the compressor is operating signifies a sufficiently charged SEA FROST BG 2000 System. To determine the meaning of "clear", notice the appearance of the RFD sight glass when the system is at rest with the compressor off. This is a "clear" glass.

SPECIAL WARNING: A clear sight glass can also indicate a completely EMPTY system. Any time the compressor is started, a white stream of foam should appear in the sight glass indicating that refrigerant is present. This foam may disappear quite quickly, but IF NO FOAM IS EVIDENT, the system is empty. DO NOT OPERATE THE SYSTEM if empty. Operation in this mode will ruin the compressor. Turn off the main breaker to prevent operation until system can be properly leak tested and recharged.

A white stream of fast moving foam with the compressor operating indicates an insufficient charge level. Watch closely for a transition from foam to total liquid, indicated by a clear sight glass. This transition point can be missed if proper attention is not given. Also, IT IS POSSIBLE for the sight glass to show large bubbles even when the charge is sufficient, so it is important to differentiate between foam and bubbles. The foam condition has velocity and direction; the bubbles are large, temporary, and nearly stationary. Do not try to chase away these larger bubbles with more refrigerant; overcharging must be avoided. Air in the system may give a false sight glass reading, which could lead to overcharging. If in doubt, discharge a suspected overcharged system and charge again. **MONITOR THE SIGHT GLASS CONTINUALLY.** The glass will not indicate when the system is overcharged.

In a warm system, when the plates are above freezing (32.F) upon start-up, the sight glass may take several minutes to clear. A cold system, in cold water, may show a clear glass within seconds of start-up.

RFD SIGHT GLASS DETAIL

| CLEAR (OR EMPTY) | STATIONARY BUBBLES | FOAM/LOW |
|------------------|--------------------|----------|
|------------------|--------------------|----------|



PROPER CHARGE AMOUNT

THE BG 2000 SYSTEM IS DESIGNED TO HOLD 24 OUNCES. THIS IS THE **MAXIMUM CHARGE**. The sight glass must clear by the time the return line (suction/large diameter tube) goes below 32 degrees F.

GENERAL INFORMATION

OPERATING PRESSURES will vary with water temperature, and water flow. Generally, the HIGH SIDE will peak with warm plates in two to four minutes. Increasing pressure indicates an overcharge or no water flow. The LOW SIDE will drop rapidly to the 20 to 10 range, and then slowly drop. The low side tubing will freeze. The low side pressure will drop more rapidly when the seawater is cold. A deep vacuum indicates the system is frozen with moisture or the valve is plugged with dirt or contaminants. Failure to "pull down" indicates the valve is malfunctioning or flooding.

The compressor will feel warm in normal operation.

Every valve has been operated prior to shipment. There are no field superheat adjustments.

SPECIAL NOTE

R-404a will become cloudy and indicate similar foaming in the sight glass as the pressure on the hi-pressure side of the systems becomes too great. Adding charge to clear this condition will damage the compressor. Be sure you know the pressures you should have for the corresponding water temperature.

CHECKING THE REFRIGERANT CHARGE

PERIODIC INSPECTION

Checking the refrigerant charge must be incorporated into a routine maintenance schedule.

- 1) Locate the RFD (receiver filter drier). It is a blue metal can about 10 inches high and three inches in diameter, with brass fittings connecting it to copper tubing. The RFD has a sight glass for viewing the flow of the refrigerant. It is located in the left corner of the compressor housing.
- 2) Start the BG 2000. Check to be sure that it is pumping water.
- 3) MONITOR THE SIGHT GLASS CONTINUALLY. If the sight glass does not show a presence of refrigerant within a minute of operation the system is empty. TURN OFF THE SYSTEM, and follow the procedure in the troubleshooting section.
- 4) If the white foam is evident watch closely for the transition to clear. If the glass indicates insufficient charge level, additional charge will be needed
- 5) Feel the SEA FROST plates in the icebox 10 minutes after start up. If the sight glass clears yet the plate's temperature does not drop, turn the system off and follow the procedure in troubleshooting section.
- 6) If the proper charge is indicated, make ice, go sailing.

DISCHARGING THE SYSTEM (RECLAIMING)

Before the connections or components can be disassembled, the system must be discharged. Connect a gauge set to the suction service port. Slowly vent the refrigerant (keeping the pressure under 20 psi) into an approved reclaiming system. Do not loosen any connections until the gauge on the refrigeration system shows 10" vacuum for 10 minutes.

TROUBLESHOOTING

The most common problems that can occur in a SEA FROST BG 2000 System are:

- (1) Overcharge or loss of water flow switching off the manual reset high-pressure switch.
- (2) Loss of refrigerant charge resulting from leaks.
- (3) Moisture or dirt plugging the expansion valve.
- (4) Compressor damage due to loss of refrigerant charge.

STEP 1. Gather information as to the nature of the problem before operating the system. A leak often leaves a trace of oil. Inspect the fittings and tubing for wear, corrosion, and chafe. Do not operate the compressor until the trouble is corrected.

HIGH PRESSURE CUTOUT/MANUAL RESET BUTTON

The compressor is fitted with a MANUAL RESET high-pressure switch. The switch is located on the left end of the BG 2000 unit. (See drawing). This switch will disconnect the thermostat circuit switching off the compressor and water pump. **Pushing the red rubber button after the unit has rested for a few minutes will reset the switch.** A faint click will be heard when the button resets.

BEFORE RESETTING the switch inspect the pump and strainer. If the installation location of the through hull allows air to enter the system it may be necessary to bleed the air from a hose connection after the pump but below the waterline by loosening a hose connection. When water flows from the connection retighten the connection.

*This switch will disconnect if the water flow stops.

*This switch will disconnect if the system is overcharged.

Overcharge may not appear until the boat moves into warmer water than it has been commissioned in. Discharge the system until the unit operates without activating the high-pressure switch. Be sure that the sight glass still runs clear. For further troubleshooting, attach purged gauges at the compressor.

a) If the refrigerator box and SEA FROST plates are warm and pressure readings are below 100psi with compressor off (in 50 degree F or higher ambient conditions), pressurize system with R-404a and leak-check. After leaks have been located, repaired, and tested, install a new RFD (Receiver/filter/drier) - see instructions below in Step 3.

b) If pressure reading is over 100 psig with compressor off, proceed to check charge level via sight glass and charge if needed.

CHARGE LOSS INDICATES A LEAK THAT MUST BE CORRECTED.

STEP 2. If a system continues to operate inefficiently after Step 1, check for moisture or dirt plugging the valve. Run the system, observing closely the gauge readings and plates temperature, noting the following.

a) If system is warm upon start-up, a DIRT-PLUGGED Valve will show an immediate deep vacuum reading on low side. Consult Sea Frost for cleaning techniques.

b) MOISTURE-PLUGGED VALVE on a properly charged system is indicated by deep vacuum readings on low side after a few minutes of operation from warm, FOLLOWED BY any combination of these symptoms:

-High side compressor discharge fitting temperature drops from hot to warm.

-Suction line from valve remains warm.

-Compressor current draw (Running amperes.) drops.

-Moisture enters either through a low side leak or during initial installation and will freeze at the valve unit, reducing or eliminating refrigeration. Turning off system and allowing the valve to warm to above freezing, then restarting, may temporarily solve the problem. If not, change RFD as follows.

STEP 3. To change a saturated RFD, allow the system to warm to ambient temperature, thereby preventing moisture from condensing in the circuit upon opening. A light bulb in the refrigerator box will speed the warming of the plates. Recover the refrigerant from system through the suction service port SLOWLY to prevent liquid and oil from escaping. " WARNING: BEFORE DISASSEMBLY OF ANY PART IN THIS SYSTEM, BE SURE CHARGE IS COMPLETELY RECOVERED. With a backup wrench holding the brass body of the Swagelok fittings loosen and back off the nuts. The tubing may be pulled out of the fittings. Remove the RFD. Replace only with an identical unit by size and color: THE SEA FROST RFD is a drier and also a receiver/filter. **The desiccant and the oil in the Sea Frost RFD are special to this system and R-404a. Using the wrong oil will destroy the system.**

NOTE: This system contains a measured amount of lubricating oil. Be sure the RFD being installed is a blue SEAFROST BG 2000 R-404-a RFD. Record all component exchanges in this on-board owner's manual.

Follow the "re-make" instructions for Swagelok fittings.

Reminder: To ensure the total removal of moisture from the system use a high vacuum pump, and evacuate the system with the highest possible plate temperature (100 degrees F.). A light bulb or heat lamp in contact with the plates is a good technique.

Recharge. Refer to "Recharging section"

MOISTURE IS A SYMPTOM. Carefully leak check the low side of the system if moisture becomes a problem. Moisture leaks in!

CALL US WITH ANY QUESTIONS
INTERNATIONAL 603-868-5720
TOLL FREE IN THE UNITED STATES,
CANADA, AND CARIBBEAN
800-435-6708
FAX 603 868 1040

SHIPPING AND MAIL:

SEA FROST
372 ROUTE 4
BARRINGTON NH 03825
USA

| BG 2000 Specifications and Operating Characteristics | | |
|---|--------------------------|--------------------------|
| | 115-volt 50/60 hz | 230-volt 50/60 hz |
| Horsepower | 1 HP | 1HP |
| Refrigerant | 404-a | 404-a |
| Oil | Polyol ester oil | Polyol ester oil |
| Locked rotor amps | 76.7 | 45 |
| Current draw with pump | 26.8 amps | 14.10 amps |
| Electrical breaker | 30 amp | 15 amp double pole |
| Maximum refrigerant charge | 24 oz | 24 oz |
| Manual reset high pressure cut-out | 325 PSIG | 325 PSIG |
| March pump | LC-3 | LC-3 |
| Integral low voltage thermostat circuit | 24-volt AC | 24-volt AC |

| Pressure trends: Gauge pressure PSIG | | |
|---|---------------------------------|---------------------------------|
| | Water temp 60 degrees F. | Water temp 80 degrees F. |
| Hi Pressure | 175 | 190 |
| Low Pressure (Warm Plates) | 30 | 30 |
| Low pressure (Cold Plates) | 7 to 5 | 7 to 5 |

Pressures are approximate: High pressure will momentarily rise beyond operating pressure until the expansion valve starts to restrict flow. Condensing pressure will be 15 degrees above water temp.

Low pressure will drop from equalized at start up to settle at the indicated low reading in a period of about 45 minutes depending on the number of plates and starting temperature. Proper thermostat set up should cycle the compressor in this low-pressure range.

THE EXPANSION VALVES HAVE BEEN FACTORY ADJUSTED FOR OPTIMUM PERFORMANCE. DO NOT ADJUST THIS VALVE FOR ANY REASON. INCORRECT SETTINGS MAY RUIN THE COMPRESSOR!

ACCESS PORT LOCATION

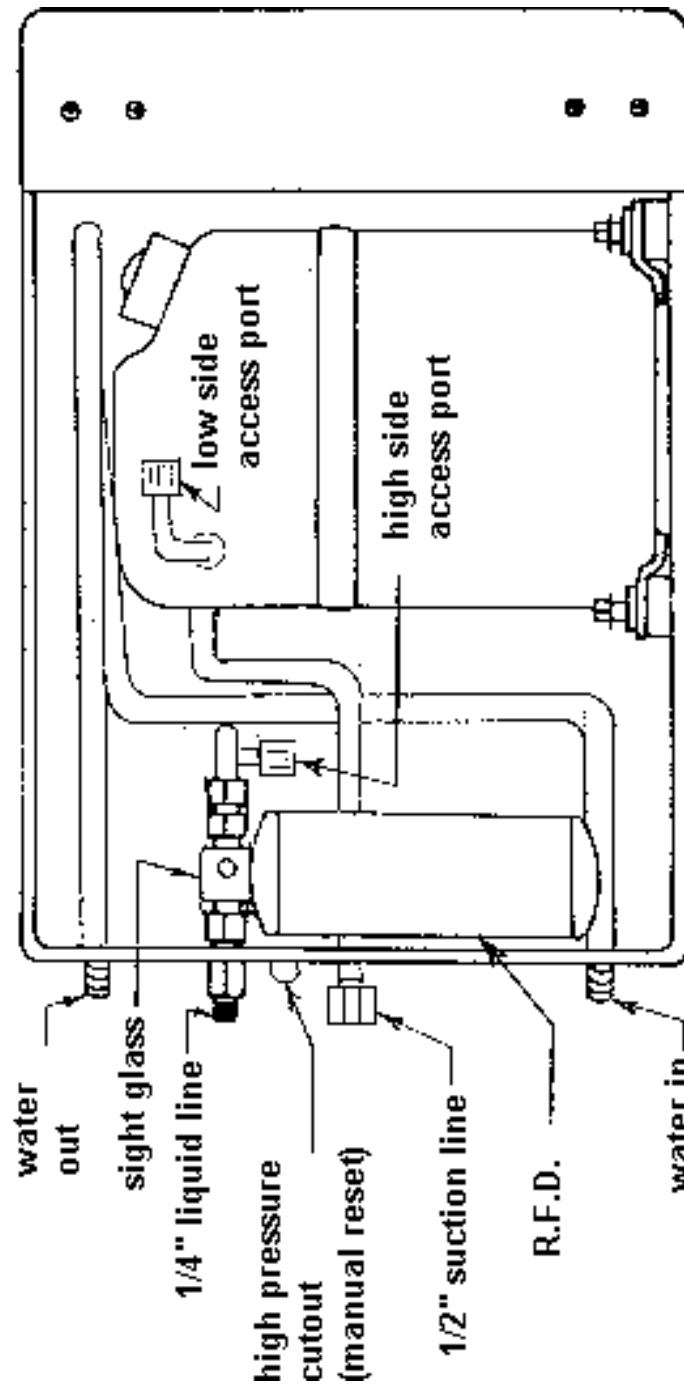
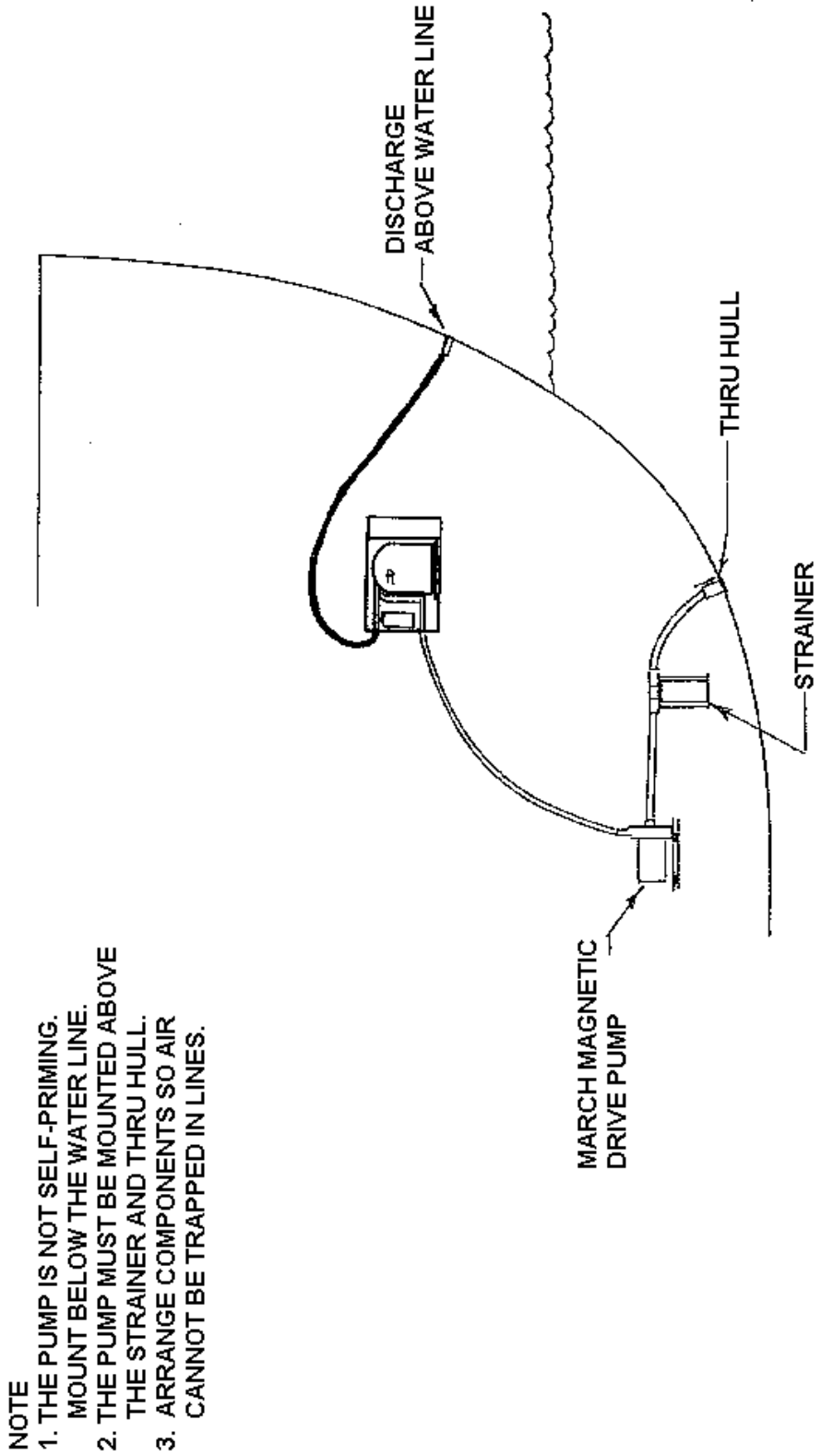
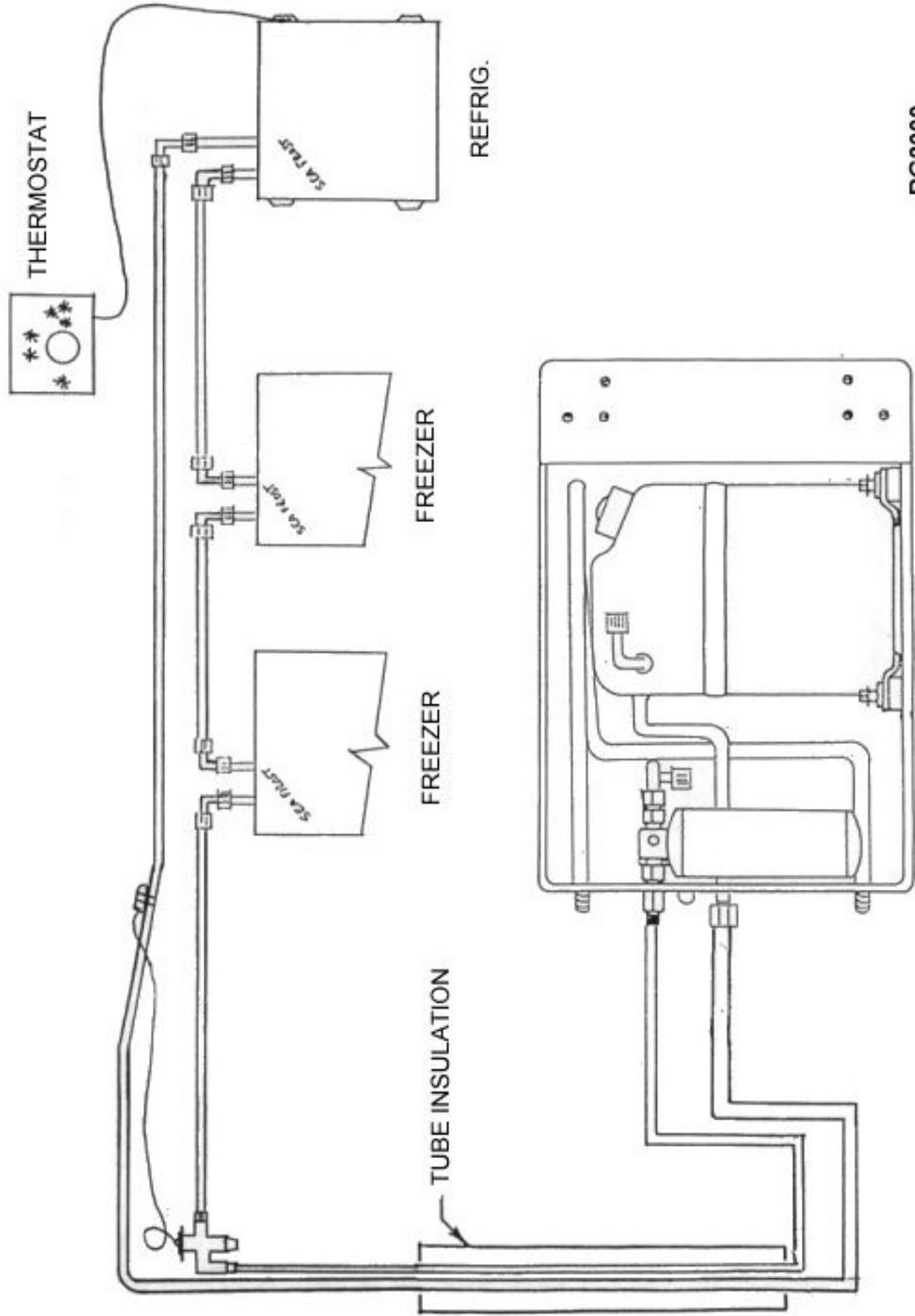

Figure 1

WATER CIRCUIT





NOTE: THIS END OF PANEL MUST BE UP. PANEL MUST BE VERTICAL TO OPERATE.

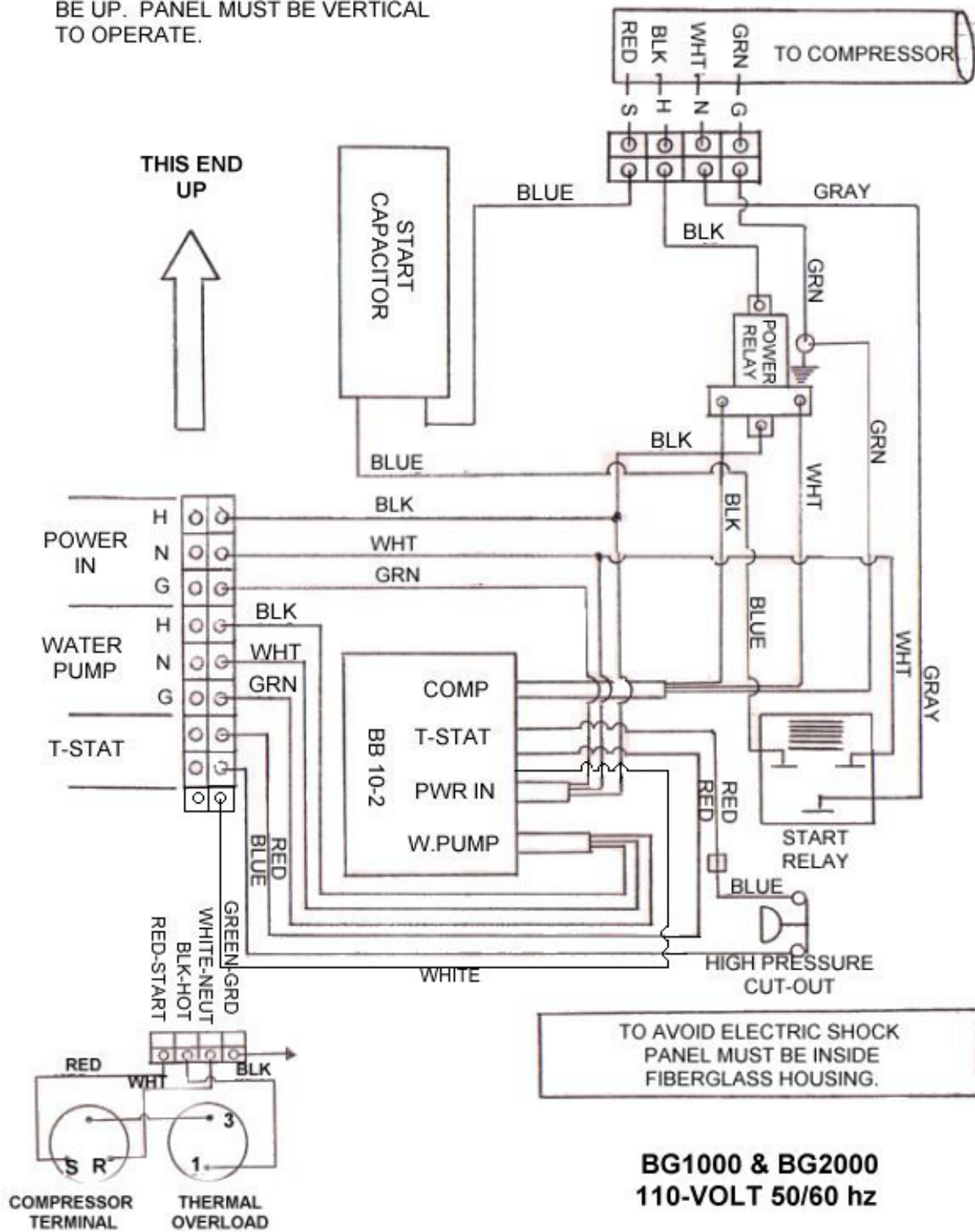

NOTE: TO AVOID ELECTRICAL SHOCK
 PANEL MUST BE MOUNTED INSIDE
 CABINET.

PANEL UP ARROW MUST BE
 UP TO OPERATE START RELAY.

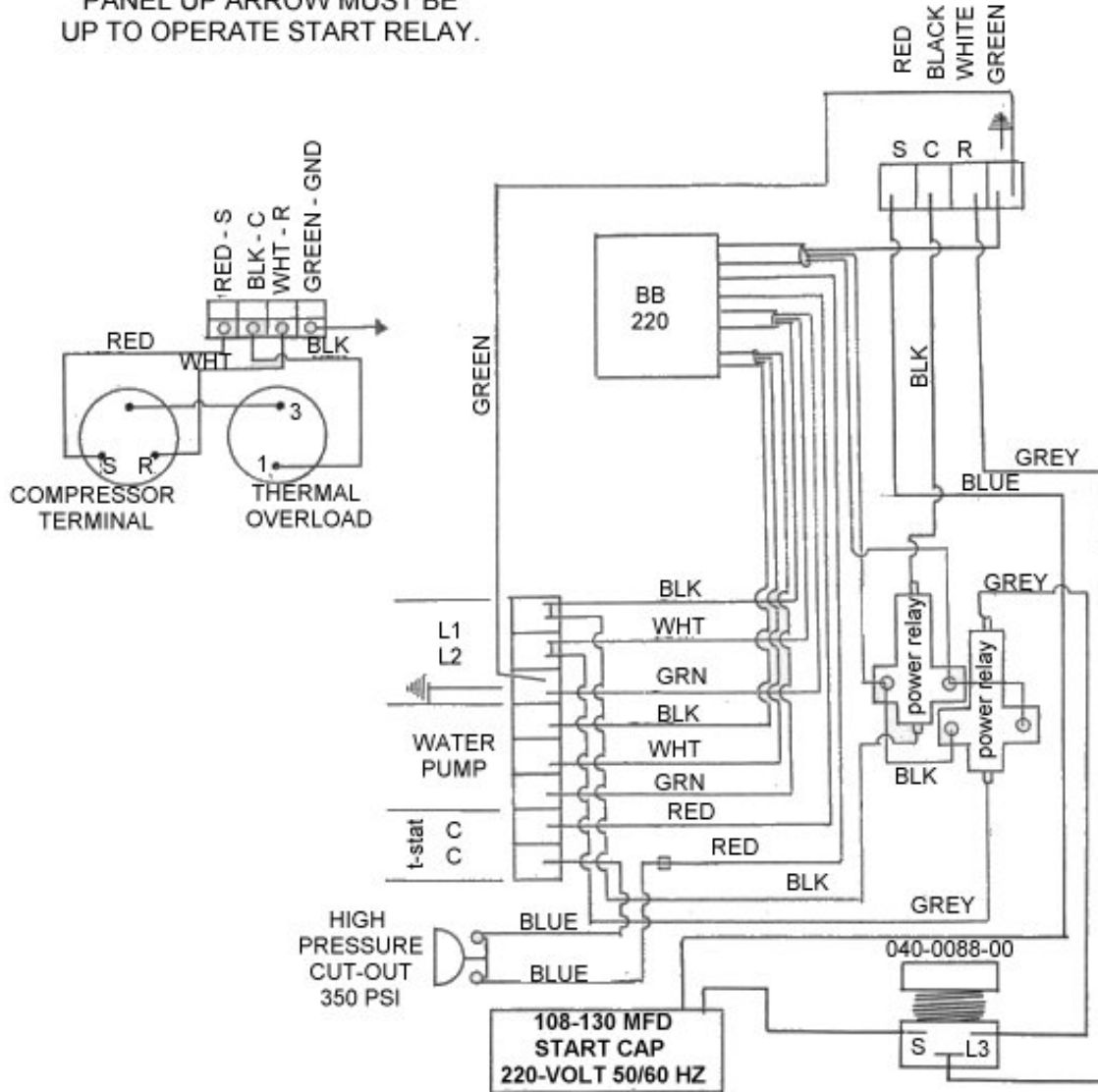

SEA FROST BG 2000
 220-VOLT 50/60 HZ

THERMOSTAT CALIBRATION INSTRUCTIONS

Note: Be sure that the unit is operating properly before making any thermostat adjustments. The sensing bulb must be in excellent thermal contact with the plate or block.

The range of this control may be changed. To access the adjustment screw, remove the four mounting screws on the thermostat panel. Tip the panel forward and remove the protective tape to expose a slot in the case. Make the adjustment with a torx or small phillips head screwdriver.

Make small adjustments. Record all adjustments.

If the lowest setting on the thermostat panel (1-snowflake) is too cold:

- Turn the adjustment screw clockwise. One 360-degree turn will raise the box temperature approximately 6 degrees f.

If the highest setting on the thermostat panel (3-snowflakes) is too warm:

- Turn the adjustment screw counterclockwise.

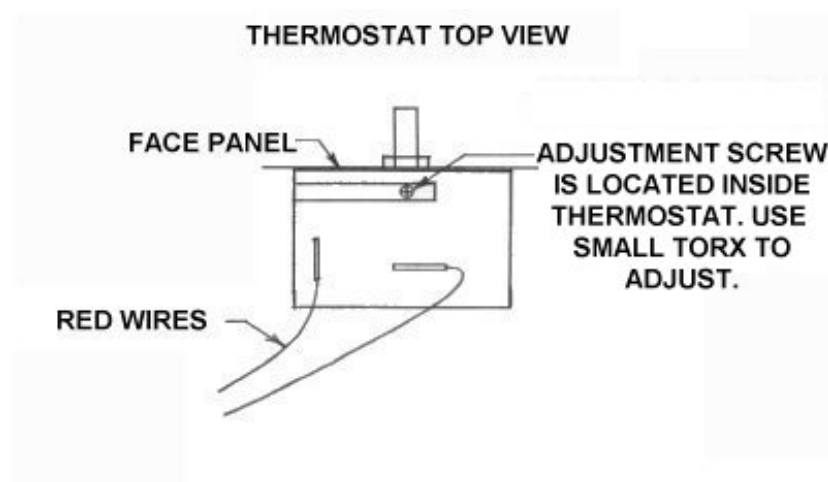

HOLDOVER PLATES

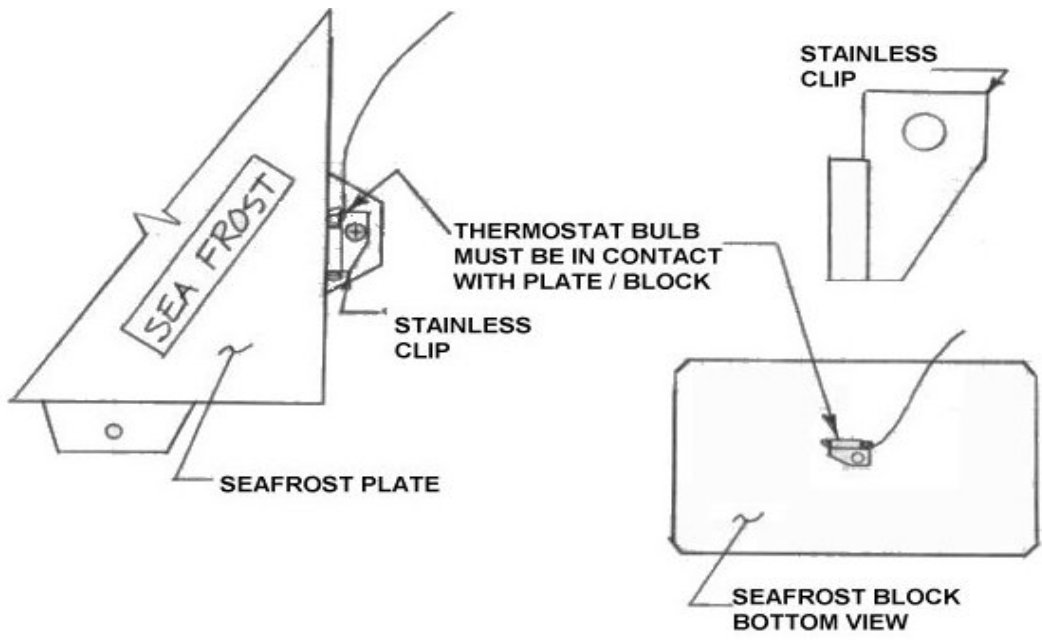

STAINLESS STEEL EVAPORATOR PLATES

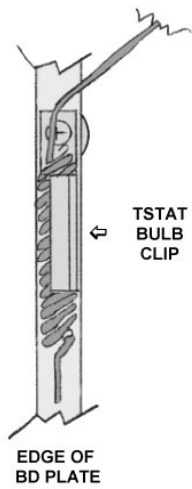

THERMOSTAT MOUNTING TEMPLATE

CUT OUT

The diagram shows a 'THERMOSTAT MOUNTING TEMPLATE' which is a rectangular frame with a smaller rectangular cutout in the center, labeled 'CUT OUT'.